

الصفحة : 1 على 11		الامتحان الوطني الموحد للبكالوريا الدورة العادية 2022		المملكة المغربية وزارة التربية الوطنية والتعليم الأولي والرياضة المركز الوطني للتقويم والامتحانات	
TTTTTTTTTTTTTTTTTTTT-TT		***I	- عناصر الإجابة -	NR 46	
8	المعامل	4h	مدة الإنجاز	علوم المهندس شعبة العلوم والتكنولوجيات: مسلك العلوم والتكنولوجيات الكهربائية	
					المادة الشعبة والمسلك

Corrigé

Monte-charge

Q.1 -

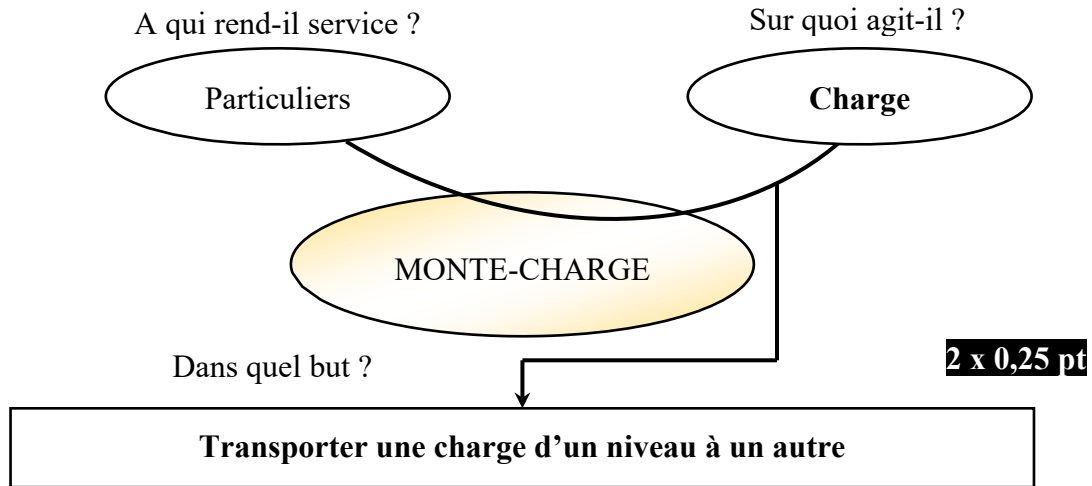

Q.2 -

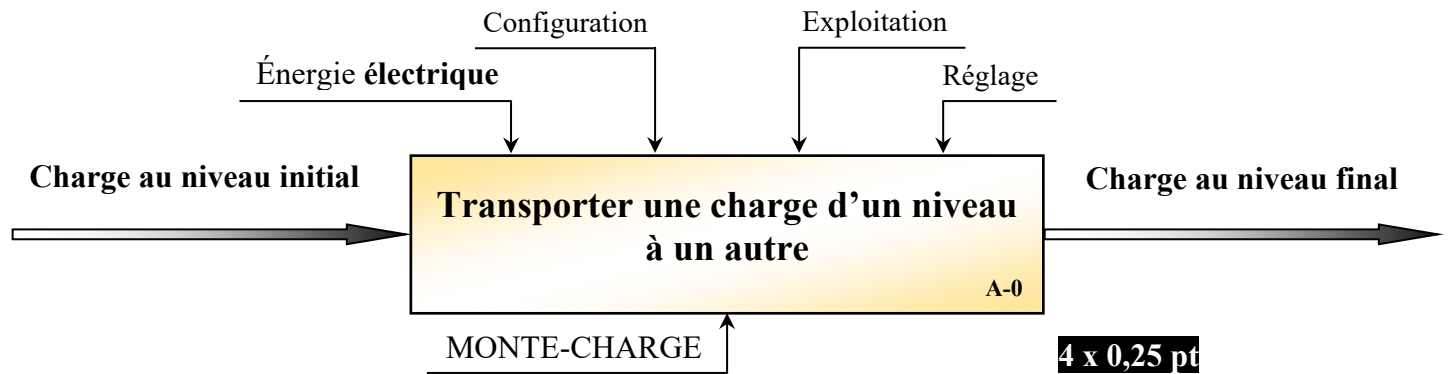

Q.3 -

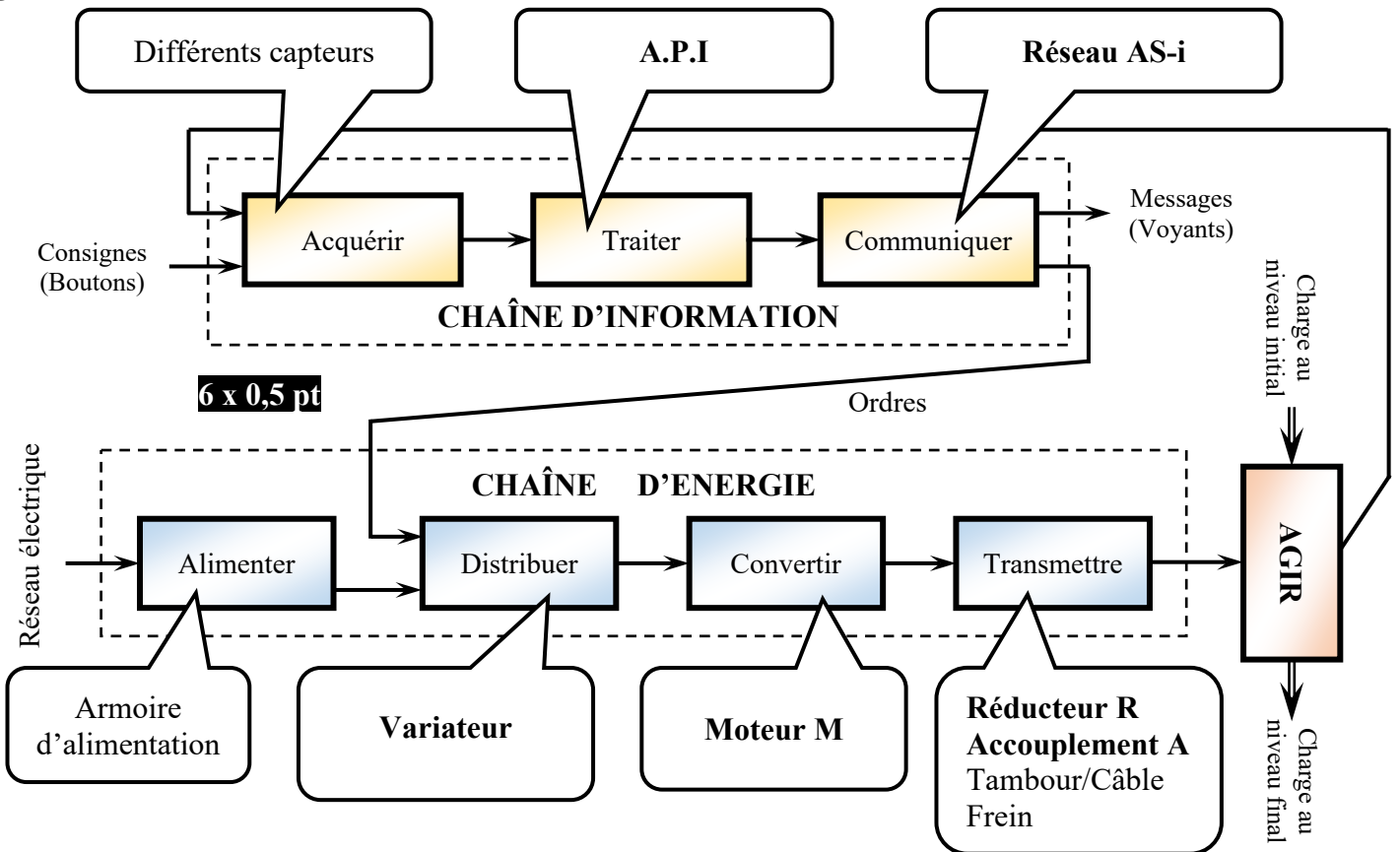

Q.4 -

4 x 0,5 pt

Liaison	Nom de la liaison	Translation d'Axe			Rotation d'axe		
		X	Y	Z	X	Y	Z
2 / 1	Encastrement	0	0	0	0	0	0
5 / 16	Encastrement	0	0	0	0	0	0
16 / {9 + 25}	Pivot	0	0	0	1	0	0
17 / 36	Encastrement	0	0	0	0	0	0
36 / {29 + 40}	Pivot	0	0	0	0	0	1

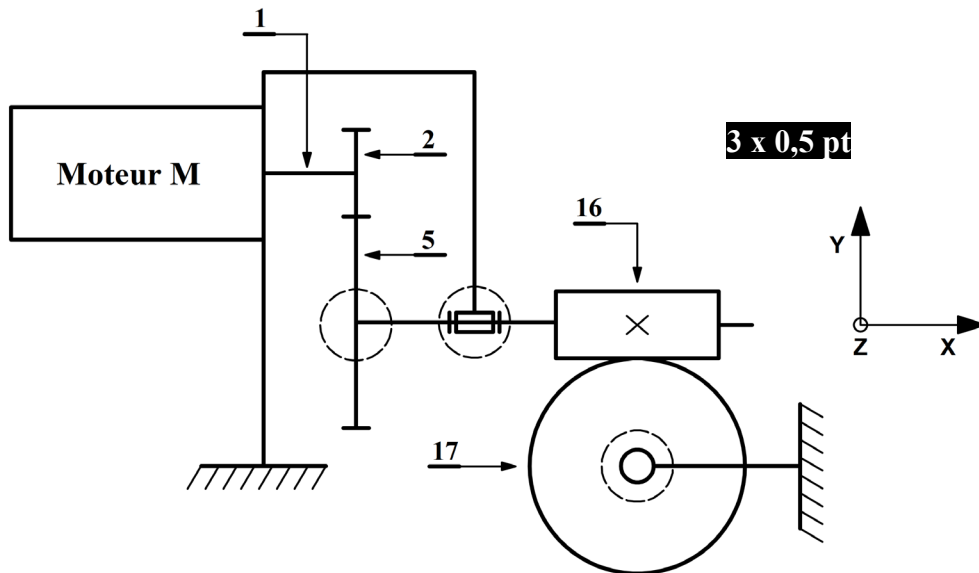

Q.5 -

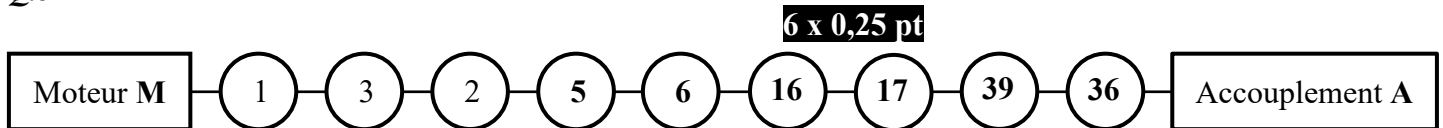

Q.6 -

Le maintien en position de la roue dentée creuse (17) est assuré par l'écrou à encoches (34) associé à la rondelle frein (35). **1 pt**

Q.7 -

$$N_T = \frac{v \cdot 60}{\pi \cdot D_T} \quad \mathbf{1 \text{ pt}} \quad \text{A.N} \quad N_T = \frac{0,2 \cdot 60 \cdot 1000}{3,14 \cdot 280}$$

$$\rightarrow N_T = 13,64 \text{ tr/min} \quad \mathbf{0,5 \text{ pt}}$$

Q.8 -

$$\omega_T = \frac{2\pi.N_T}{60} \quad \mathbf{0,5 \text{ pt}} \quad \text{A.N} \quad \omega_T = \frac{2.3.14.14}{60}$$

$$\rightarrow \omega_T = 1,46 \text{ rad/s} \quad \mathbf{0,5 \text{ pt}}$$

Q.9 -

$$P_n = m \cdot g \cdot v \quad \mathbf{0,5 \text{ pt}} \quad \text{A.N} \quad P_n = 1000 \cdot 10 \cdot 0,2$$

$$\rightarrow P_n = 2 \text{ kW} \quad \mathbf{0,5 \text{ pt}}$$

Q.10 -

$$C_T = m \cdot g \cdot R_T \quad \mathbf{1 \text{ pt}} \quad \text{A.N} \quad C_T = \frac{1000 \cdot 10 \cdot 140}{1000}$$

$$\rightarrow C_T = 1400 \text{ N.m} \quad \mathbf{0,5 \text{ pt}}$$

Q.11 -

$$\eta_g = \frac{P_n}{P_M} \quad \rightarrow \quad \eta_T \cdot \eta_A \cdot \eta_R = \frac{P_n}{P_M}$$

$$\rightarrow P_M = \frac{P_n}{\eta_T \cdot \eta_A \cdot \eta_R} \quad \mathbf{1 \text{ pt}}$$

$$\text{A.N} \quad P_M = \frac{2}{0,8 \cdot 1,0 \cdot 0,64} \quad \rightarrow \quad P_M = 3,90 \text{ kW} \quad \mathbf{0,5 \text{ pt}}$$

Q.12 -

$$r_g = \frac{N_T}{N_M} \quad \rightarrow \quad r_R = \frac{N_T}{N_M}$$

$$\rightarrow N_M = \frac{N_T}{r_R} \quad \mathbf{1 \text{ pt}}$$

$$\text{A.N} \quad N_M = 14 \cdot 70 \quad \rightarrow \quad N_M = 980 \text{ tr/min} \quad \mathbf{0,5 \text{ pt}}$$

Q.13 -

$$C_F \geq C_M$$

$$C_F \geq (P_M \cdot 60) / (2 \cdot \pi \cdot N_M)$$

$$C_F \geq (4000 \cdot 60) / (2 \cdot 3,14 \cdot 965)$$

$$C_F \geq 39,60 \text{ N.m} \quad \mathbf{1 \text{ pt}}$$

$$C_F \text{ mini} = 39,60 \text{ N.m} \quad \mathbf{0,5 \text{ pt}}$$

Q.14 -

- Vue de face ; **1 pt**
- Vue de gauche en coupe A-A (sans traits cachés) ; **1 pt**
- Vue de dessus ; **1,5 pt**
- Représentation et respect des règles du dessin. **0,5 pt**

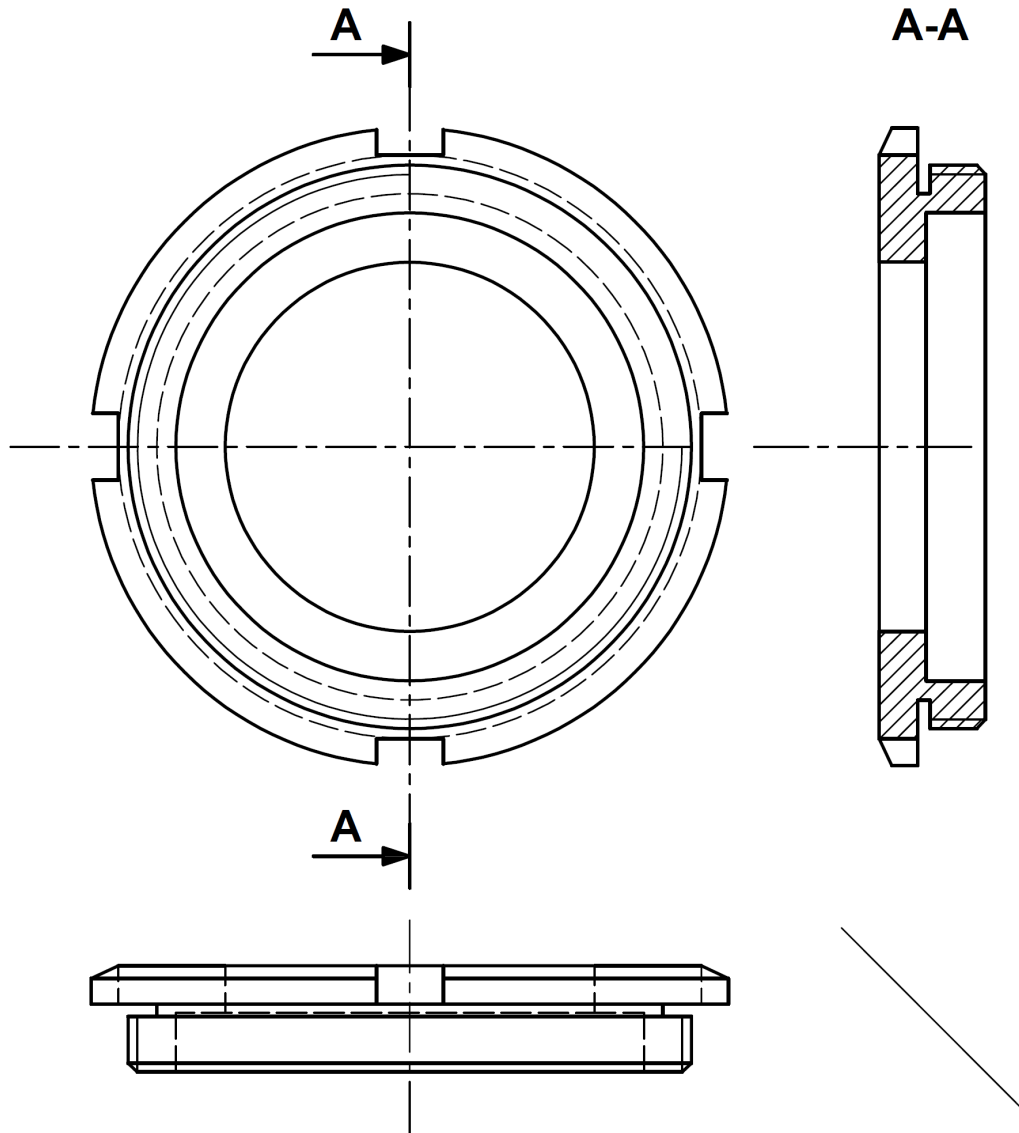
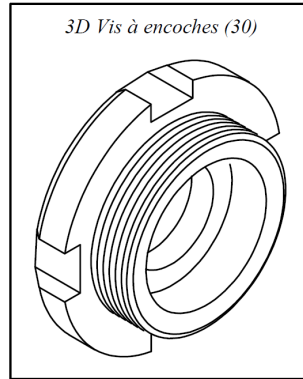

Q.15 -

Couplage étoile **1 pt**

Q.16 -

$$ns = \frac{f}{p} \cdot 60 \quad \mathbf{1 \text{ pt}} \quad \text{A.N} \quad ns = \frac{50}{3} \cdot 60 = 1000 \text{ tr/min} \quad \mathbf{0,5 \text{ pt}}$$

Q.17 -

$$g_N = \frac{ns-n}{ns} \quad \mathbf{1 \text{ pt}} \quad \text{A.N} \quad g_N = \frac{1000-960}{1000} = 0,04 = 4 \% \quad \mathbf{0,5 \text{ p}}$$

Q.18 -

$$P = \sqrt{3} \cdot U \cdot I \cdot \cos\varphi \quad \mathbf{1 \text{ pt}} \quad \text{A.N} \quad P = \sqrt{3} \times 400 \times 9,4 \times 0,76 = 4949,5 \text{ W} \quad \mathbf{0,5 \text{ pt}}$$

Q.19 -

$$\eta = \frac{P_u}{P} \quad \mathbf{1 \text{ pt}} \quad \text{A.N} \quad \eta = \frac{4000}{4949,5} = 0,80 \quad \mathbf{0,5 \text{ pt}}$$

Q.20 -

$$C_u = \frac{P_u}{\Omega} = \frac{P_u}{\frac{2\pi n}{60}} \quad \mathbf{1 \text{ pt}} \quad \text{A.N} \quad C_u = \frac{4000 \times 60}{2\pi \times 960} = 39,78 \text{ Nm} \quad \mathbf{0,5 \text{ pt}}$$

Q.21 -

Équation de la caractéristique du moteur $C_u = a \cdot n + b$ il faut déterminer a et b

Les 2 points de la droite donnent le système suivant :

$$\begin{cases} 0 = a \cdot 1000 + b & (1) \\ 39,78 = a \cdot 960 + b & (2) \end{cases}$$

$$\begin{cases} 0 = a \cdot 1000 + b & (1) \\ 39,78 = a \cdot 960 + b & (2) \end{cases}$$

$$(1) - (2) \Leftrightarrow -39,78 = a \cdot 40 \rightarrow a = -39,78/40 \quad a = -0,99 \text{ N.m/tr/min} \quad \mathbf{1 \text{ pt}}$$

$$(1) \rightarrow b = -a \cdot 1000 = 990 \text{ N.m} \quad \mathbf{1 \text{ pt}}$$

Q.22 -

$$\text{Donc } C_m = -0,99 \cdot n + 990 \text{ et } C_r = 36 \rightarrow C_m = C_r \rightarrow n = \frac{990-36}{0,99} = 964 \text{ tr/min} \quad \mathbf{1 \text{ pt}}$$

Q.23 -

$$g_1 = \frac{ns_1-n_1}{ns_1} \rightarrow ns_1 = \frac{n_1}{1-g} \quad \mathbf{1 \text{ pt}} \quad \text{A.N} \quad ns_1 = \frac{570}{1-0,05} = 600 \text{ tr/min} \quad \mathbf{0,5 \text{ pt}}$$

Q.24 -

$$f_1 = \frac{ns_1}{60} \cdot p \quad \mathbf{1 \text{ pt}} \quad \text{A.N} \quad f_1 = \frac{600}{60} \times 3 = 30 \text{ Hz} \quad \mathbf{0,5 \text{ pt}}$$

Q.25 -

$$\frac{U}{f} = \frac{U_1}{f_1} \rightarrow U_1 = U \cdot \frac{f_1}{f} \quad \mathbf{1 \text{ pt}} \quad \text{A.N} \quad U_1 = U \cdot \frac{f_1}{f} = 400 \times \frac{30}{50} = 240 \text{ V} \quad \mathbf{0,5 \text{ pt}}$$

Q.26 -

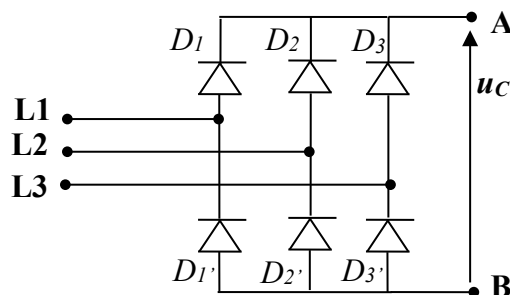
**1,5 pt**

Q.27 - 1,5 pt

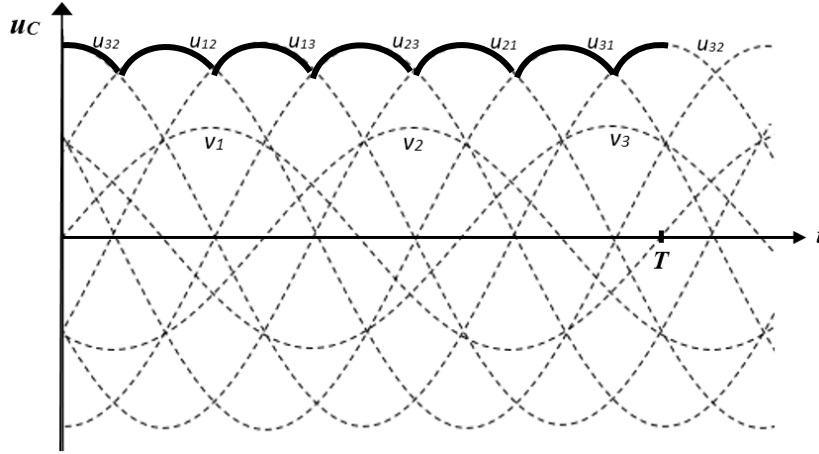

Q.28 -

$$f' = 6.f \quad \mathbf{0,5 \text{ pt}} \quad \text{A.N} \quad f' = 6.50 \quad \rightarrow \quad f' = 300 \text{ Hz} \quad \mathbf{0,5 \text{ pt}}$$

Q.29 - 1 pt

Filtre passe-bas

Q.30 - 1 pt

Conversion 'continu - alternatif'

Q.31 - 1 pt

Commande symétrique

Q.32 - 1 pt

Thyristor ou transistor de commutation

Q.33 -

$$f = \frac{1}{T} \quad \mathbf{0,5 \text{ pt}} \quad \text{A.N} \quad f = \frac{1}{0,02} \quad \rightarrow \quad f = 50 \text{ Hz} \quad \mathbf{0,5 \text{ pt}}$$

Q.34 - 1,5 pt

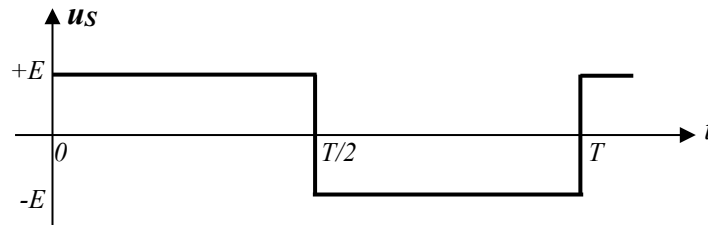

Q.35 -

$$U_s = E \quad \mathbf{1 \text{ pt}}$$

Q.36 -

$$s = \frac{U_{AB}}{E} \rightarrow U_{AB} = s \cdot E \quad \mathbf{1 \text{ pt}}$$

$$U_{AB} = 2 \cdot 10^{-3} \cdot 10 \rightarrow U_{AB} = 20 \cdot 10^{-3} \text{ V} \quad \mathbf{0,5 \text{ pt}}$$

Q.37 -

En pleine charge $s = 2 \text{ mV/V}$ et $s = \frac{U_{AB}}{E} = \frac{\Delta R}{R} = K \cdot m$ donc $K = \frac{s}{m}$

$$K = \frac{2 \cdot 10^{-3}}{1000} \rightarrow K = 2 \cdot 10^{-6} \quad \mathbf{1 \text{ pt}} \quad \text{kg}^{-1} \quad (\text{unité } \mathbf{0,5 \text{ pt}})$$

Q.38 -

$$U_{AB} = E \cdot \frac{\Delta R}{R} \rightarrow U_{AB} = E \cdot K \cdot m \quad \mathbf{1 \text{ pt}}$$

$$U_{AB} = 10 \cdot 2 \cdot 10^{-6} \cdot m \rightarrow U_{AB} = 2 \cdot 10^{-5} \cdot m \quad \mathbf{0,5 \text{ pt}}$$

Q.39 -

$$C_S = \text{pleine échelle} \cdot 150 \% \quad \mathbf{0,5 \text{ pt}}$$

$$C_S = 1000 \cdot \frac{150}{100} \rightarrow C_S = 1500 \text{ Kg} \quad \mathbf{0,5 \text{ pt}}$$

$$C_R = \text{pleine échelle} \cdot 300 \% \quad \mathbf{0,5 \text{ pt}}$$

$$C_R = 1000 \cdot \frac{300}{100} \rightarrow C_R = 3000 \text{ Kg} \quad \mathbf{0,5 \text{ pt}}$$

Q.40 -

$$V^+ = U_1 \cdot \frac{R_8}{R_8 + R_7} \quad \mathbf{0,5 \text{ pt}} \quad \text{et} \quad V^- = \frac{U_2 \cdot R_8 + U_3 \cdot R_7}{R_8 + R_7} \quad \mathbf{0,5 \text{ pts}}$$

$$\text{Mode linéaire : } V^+ = V^- \rightarrow U_1 \cdot \frac{R_8}{R_8 + R_7} = \frac{U_2 \cdot R_8 + U_3 \cdot R_7}{R_8 + R_7}$$

$$\rightarrow U_1 \cdot R_8 = U_2 \cdot R_8 + U_3 \cdot R_7 \rightarrow U_3 \cdot R_7 = U_1 \cdot R_8 - U_2 \cdot R_8$$

$$\rightarrow U_3 = \frac{R_8}{R_7} \cdot (U_1 - U_2) \quad \mathbf{1 \text{ pt}}$$

Q.41 -

$$U_3 = \frac{R_8}{R_7} \cdot (U_1 - U_2) \rightarrow U_3 = U_1 - U_2$$

$$U_3 = 51 \cdot V_B - 50 \cdot V_A - 51 \cdot V_A + 50 \cdot V_B \rightarrow U_3 = 101 \cdot V_B - 101 \cdot V_A$$

$$\rightarrow U_3 = 101 \cdot (V_B - V_A) \rightarrow U_3 = -101 \cdot U_{AB} \quad \mathbf{1,5 \text{ pt}}$$

$$U_3 = -101 \cdot E \cdot K \cdot m \rightarrow U_3 = -2,02 \cdot 10^{-3} \cdot m \quad \mathbf{0,5 \text{ pt}}$$

Q.42 -

$$V^+ = 0$$

$$V^- = \frac{\frac{U_3}{R_9} + \frac{U_{RF1}}{R_9} + \frac{U_4}{R_{10}}}{\frac{1}{R_9} + \frac{1}{R_9} + \frac{1}{R_{10}}}$$

$$\text{Mode linéaire : } V^+ = V^- = 0 \rightarrow \frac{U_3}{R_9} + \frac{U_{RF1}}{R_9} + \frac{U_4}{R_{10}} = 0$$

$$\rightarrow \frac{U_4}{R_{10}} = -\frac{U_3}{R_9} - \frac{U_{RF1}}{R_9} \rightarrow U_4 = -\frac{R_{10}}{R_9} \cdot (U_3 + U_{RF1}) \quad \mathbf{2 \text{ pts}}$$

Q.43 -

$$U_4 = -\frac{R_{10}}{R_9} \cdot (-2,02 \cdot 10^{-3} \cdot (m_0 + m_C) + U_{RF1})$$

$$\rightarrow U_4 = -\frac{R_{10}}{R_9} \cdot (-2,02 \cdot 10^{-3} \cdot 200 - 2,02 \cdot 10^{-3} \cdot m_C + U_{RF1})$$

$$\rightarrow U_4 = -\frac{R_{10}}{R_9} \cdot (-0,404 - 2,02 \cdot 10^{-3} \cdot m_C + U_{RF1}) \rightarrow U_4 = 2,02 \cdot 10^{-3} \cdot \frac{R_{10}}{R_9} \cdot m_C \quad \mathbf{1 \text{ pt}}$$

Q.44 -

$$U_4 = 2,02 \cdot 10^{-3} \cdot \frac{R_{10}}{R_9} \cdot m_C \rightarrow \frac{R_{10}}{R_9} = \frac{U_4}{2,02 \cdot 10^{-3} \cdot m_C}$$

$$\rightarrow R_{10} = \frac{U_4}{2,02 \cdot 10^{-3} \cdot m_C} \cdot R_9 \quad \mathbf{1 \text{ pt}}$$

$$\rightarrow R_{10} = \frac{5}{2,02 \cdot 10^{-3} \cdot 800} \cdot 22 \rightarrow R_{10} = 68,07 \text{ K}\Omega \quad \mathbf{0,5 \text{ pt}}$$

Q.45 -

$$U_{RF2} = U_4(700 \text{ kg}) \quad \mathbf{1 \text{ pt}} \rightarrow U_{RF2} = 2,02 \cdot 10^{-3} \cdot \frac{68}{22} \cdot 700$$

$$\rightarrow U_{RF2} = 4,37 \text{ V} \quad \mathbf{0,5 \text{ pt}}$$

Q.46 -

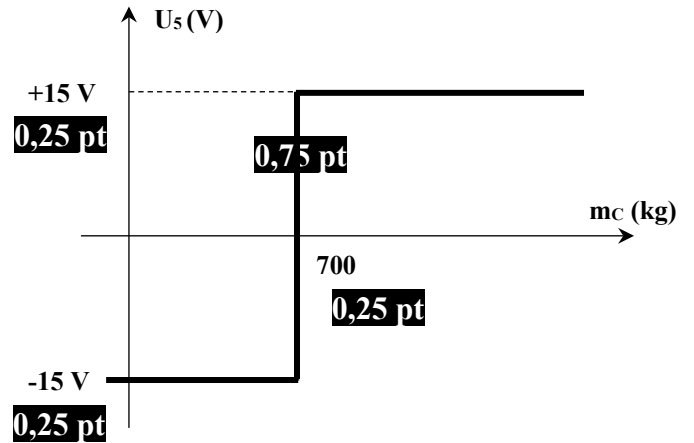
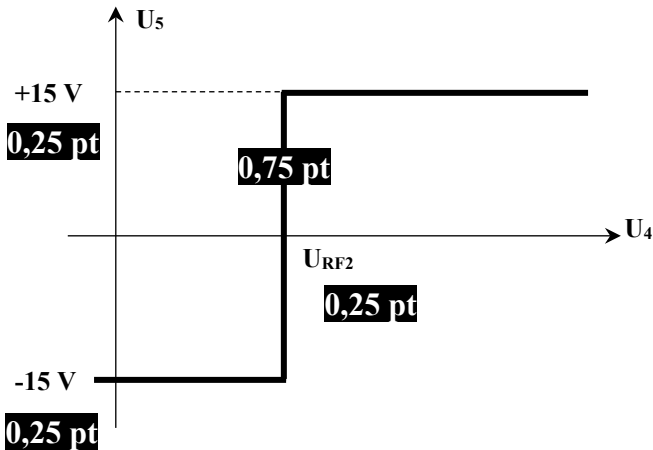

Q.47 -

8 x 0,5 pt

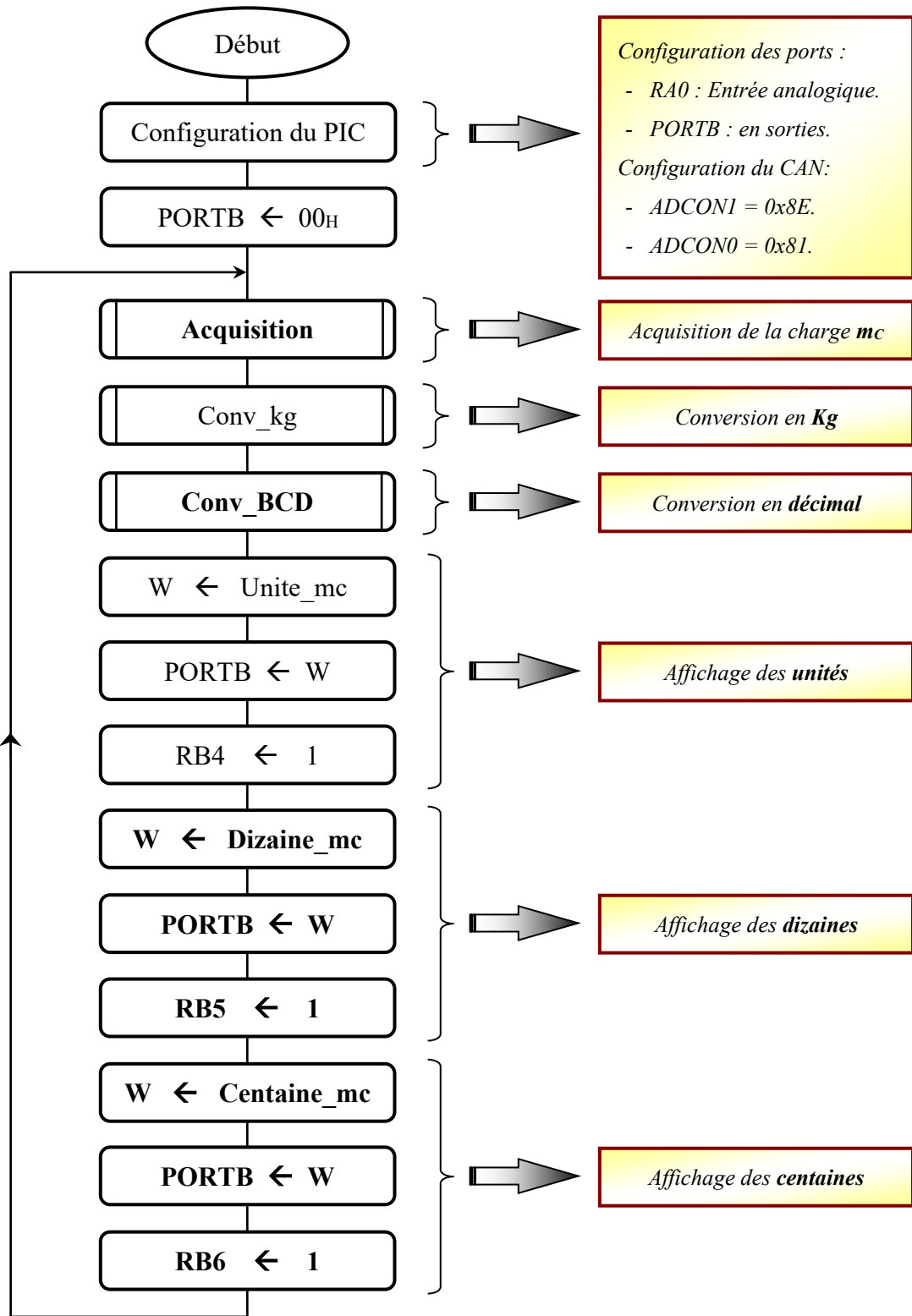

Q.48 -

10 x 0,5 pt

Loop

BCF	STATUS, 6	;
BSF	STATUS, 5	; accès à la BANK 1
CLRF	TRISB	; PORTB en sortie
MOVLW	0x01	; Mot de commande du registre TRISA
MOVWF	TRISA	; RA0 en entrée
MOVLW	0x8E	; Mot de commande du registre ADCON1
MOVWF	ADCON1	; Configuration du CAN interne
BCF	STATUS, 5	; Retour en banque mémoire 0
MOVLW	0x81	; Mot de commande du registre ADCON0
MOVWF	ADCON0	; Configuration du CAN interne
CLRF	PORTB	; Initialisation des sorties
CALL	Acquisition	; appel du sous-programme "Acquisition"
CALL	Conv_kg	; appel du sous-programme "Conv_Kg"
CALL	Conv_BCD	; appel du sous-programme "Conv_BCD"
MOVF	Unite_mc, W	; Lecture de la valeur des unités
MOVWF	PORTB	; Ecriture des unités dans le PORTB
BSF	PORTB, 4	; Affichage des unités
MOVF	Dizaine_mc, W	; Lecture de la valeur des dizaines
MOVWF	PORTB	; Ecriture des dizaines dans le PORTB
BSF	PORTB, 5	; Affichage des dizaines
MOVF	Centaine_mc, W	; Lecture de la valeur des centaines
MOVWF	PORTB	; Ecriture des centaines dans le PORTB
BSF	PORTB, 6	; Affichage des centaines
GOTO	Loop	;